

# COMLINEAR<sup>®</sup> CLC1050, CLC2050, CLC4050

## Low Power, 3V to 36V, Single, Dual, Quad Amplifiers

### FEATURES

- Unity gain stable
- 100dB voltage gain
- 550kHz unity gain bandwidth
- 0.5mA supply current
- 20nA input bias current
- 2mV input offset voltage
- 3V to 36V single supply voltage range
- ±1.5V to ±18V dual supply voltage range
- Input common mode voltage range includes ground
- 0V to  $V_S - 1.5V$  output voltage swing
- CLC2050: improved replacement for industry standard LM358
- CLC4050: Improved replacement for industry standard LM324
- CLC1050: Pb-free SOT23-5
- CLC2050: Pb-free SOIC-8
- CLC4050: Pb-free SOIC-14

### APPLICATIONS

- Battery Charger
- Active Filters
- Transducer amplifiers
- General purpose controllers
- General purpose instruments

### General Description

The COMLINEAR CLC1050 (single), CLC2050 (dual), and CLC4050 (quad) are voltage feedback amplifiers that are internally frequency compensated to provide unity gain stability. At unity gain ( $G=1$ ), these amplifiers offer 550kHz of bandwidth. They consume only 0.5mA of supply current over the entire power supply operating range. The CLC1050, CLC2050, and CLC4050 are specifically designed to operate from single or dual supply voltages.

The COMLINEAR CLC1050, CLC2050, and CLC4050 offer a common mode voltage range that includes ground and a wide output voltage swing. The combination of low-power, high supply voltage range, and xxx make these amplifier well suited for many general purpose applications and as alternatives to several industry standard amplifiers on the market today.

### Typical Application - Voltage Controlled Oscillator (VCO)

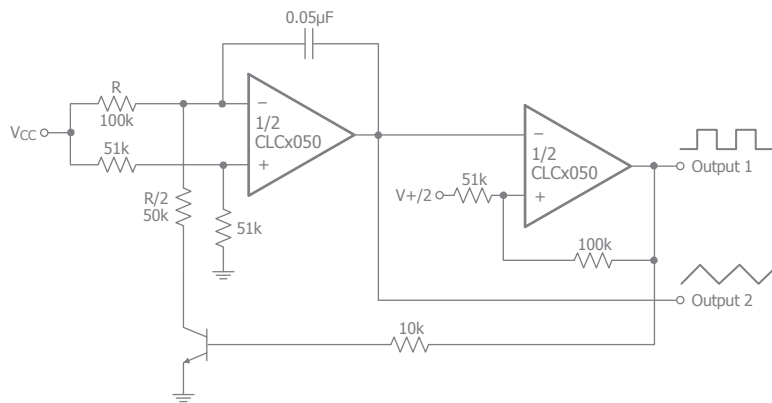

### Ordering Information

| Part Number   | Package | Pb-Free | RoHS Compliant | Operating Temperature Range | Packaging Method |
|---------------|---------|---------|----------------|-----------------------------|------------------|
| CLC1050IST5X  | SOT23-5 | Yes     | Yes            | -40°C to +85°C              | Reel             |
| CLC2050ISO8X  | SOIC-8  | Yes     | Yes            | -40°C to +85°C              | Reel             |
| CLC4050ISO14X | SOIC-14 | Yes     | Yes            | -40°C to +85°C              | Reel             |

Moisture sensitivity level for all parts is MSL-1.



### CLC1050 Pin Configuration

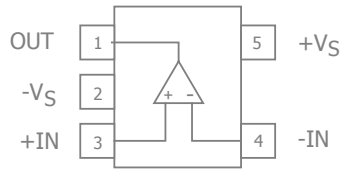

### CLC1050 Pin Assignments

| Pin No. | Pin Name | Description     |
|---------|----------|-----------------|
| 1       | OUT      | Output          |
| 2       | -VS      | Negative supply |
| 3       | +IN      | Positive input  |
| 4       | -IN      | Negative input  |
| 5       | +VS      | Positive supply |

### CLC2050 Pin Configuration

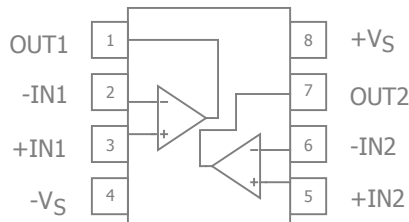

### CLC2050 Pin Configuration

| Pin No. | Pin Name | Description               |
|---------|----------|---------------------------|
| 1       | OUT1     | Output, channel 1         |
| 2       | -IN1     | Negative input, channel 1 |
| 3       | +IN1     | Positive input, channel 1 |
| 4       | -VS      | Negative supply           |
| 5       | +IN2     | Positive input, channel 2 |
| 6       | -IN2     | Negative input, channel 2 |
| 7       | OUT2     | Output, channel 2         |
| 8       | +VS      | Positive supply           |

### CLC4050 Pin Configuration

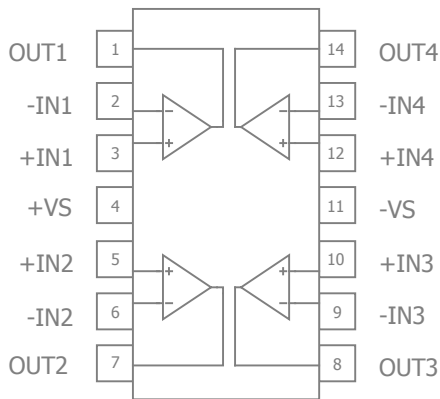

### CLC4050 Pin Configuration

| Pin No. | Pin Name | Description               |
|---------|----------|---------------------------|
| 1       | OUT1     | Output, channel 1         |
| 2       | -IN1     | Negative input, channel 1 |
| 3       | +IN1     | Positive input, channel 1 |
| 4       | +VS      | Positive supply           |
| 5       | +IN2     | Positive input, channel 2 |
| 6       | -IN2     | Negative input, channel 2 |
| 7       | OUT2     | Output, channel 2         |
| 8       | OUT3     | Output, channel 3         |
| 9       | -IN3     | Negative input, channel 3 |
| 10      | +IN3     | Positive input, channel 3 |
| 11      | -VS      | Negative supply           |
| 12      | +IN4     | Positive input, channel 4 |
| 13      | -IN4     | Negative input, channel 4 |
| 14      | OUT4     | Output, channel 4         |



## Absolute Maximum Ratings

The safety of the device is not guaranteed when it is operated above the "Absolute Maximum Ratings". The device should not be operated at these "absolute" limits. Adhere to the "Recommended Operating Conditions" for proper device function. The information contained in the Electrical Characteristics tables and Typical Performance plots reflect the operating conditions noted on the tables and plots.

| Parameter  | Min  | Max | Unit |
|--|------|-----|------|
| Supply Voltage   | 0    | 40  | V    |
| Differential Input Voltage                               |      | 40  | V    |
| Input Voltage  | -0.3 | 40  | V    |
| Power Dissipation ( $T_A = 25^\circ\text{C}$ ) - SOIC-8  |      | 550 | mW   |
| Power Dissipation ( $T_A = 25^\circ\text{C}$ ) - SOIC-14 |      | 800 | mW   |

## Reliability Information

| Parameter                         | Min | Typ | Max | Unit                      |
|-----------------------------------|-----|-----|-----|---------------------------|
| Junction Temperature              |     |     | 150 | $^\circ\text{C}$          |
| Storage Temperature Range         | -65 |     | 150 | $^\circ\text{C}$          |
| Lead Temperature (Soldering, 10s) |     |     | 260 | $^\circ\text{C}$          |
| Package Thermal Resistance        |     |     |     |                           |
| SOT23-5                           |     | 221 |     | $^\circ\text{C}/\text{W}$ |
| SOIC-8                            |     | 100 |     | $^\circ\text{C}/\text{W}$ |
| SOIC-14                           |     | 88  |     | $^\circ\text{C}/\text{W}$ |

Notes:

Package thermal resistance ( $\theta_{JA}$ ), JEDEC standard, multi-layer test boards, still air.

## Recommended Operating Conditions

| Parameter                   | Min | Typ | Max | Unit             |
|-----------------------------|-----|-----|-----|------------------|
| Operating Temperature Range | -40 |     | +85 | $^\circ\text{C}$ |
| Supply Voltage Range        | 3   |     | 36  | V                |



## Electrical Characteristics

$T_A = 25^\circ\text{C}$  (if **bold**,  $T_A = -40$  to  $+85^\circ\text{C}$ ),  $V_S = +5\text{V}$ ,  $-V_S = \text{GND}$ ,  $R_f = R_g = 2\text{k}\Omega$ ,  $R_L = 2\text{k}\Omega$  to  $V_S/2$ ,  $G = 2$ ; unless otherwise noted.

| Symbol                    | Parameter                                   | Conditions  | Min       | Typ         | Max          | Units                        |
|---------------------------|---|---|-----------|-------------|--------------|------------------------------|
| Frequency Domain Response |   |   |           |             |              |                              |
| UGBW <sub>SS</sub>        | Unity Gain Bandwidth                        | $G = +1, V_{\text{OUT}} = 0.2V_{\text{pp}}, V_S = 5\text{V}$  |           | 330         |              | kHz                          |
|                           |   | $G = +1, V_{\text{OUT}} = 0.2V_{\text{pp}}, V_S = 30\text{V}$   |           | 550         |              | kHz                          |
| BW <sub>SS</sub>          | -3dB Bandwidth                              | $G = +2, V_{\text{OUT}} = 0.2V_{\text{pp}}, V_S = 5\text{V}$  |           | 300         |              | kHz                          |
|                           |   | $G = +1, V_{\text{OUT}} = 0.2V_{\text{pp}}, V_S = 30\text{V}$   |           | 422         |              | kHz                          |
| BW <sub>LS</sub>          | Large Signal Bandwidth                      | $G = +2, V_{\text{OUT}} = 1V_{\text{pp}}, V_S = 5\text{V}$  |           | 107         |              | kHz                          |
|                           |   | $G = +2, V_{\text{OUT}} = 2V_{\text{pp}}, V_S = 30\text{V}$   |           | 76          |              | kHz                          |
| Time Domain Response      |   |   |           |             |              |                              |
| $t_r, t_f$                | Rise and Fall Time                          | $V_{\text{OUT}} = 1\text{V}$ step; (10% to 90%), $V_S = 5\text{V}$  |           | 4           |              | $\mu\text{s}$                |
|                           |   | $V_{\text{OUT}} = 2\text{V}$ step; (10% to 90%), $V_S = 30\text{V}$                                       |           | 5.6         |              | $\mu\text{s}$                |
| OS                        | Overshoot                                   | $V_{\text{OUT}} = 0.2\text{V}$ step   |           | 1           |              | %                            |
| SR                        | Slew Rate                                   | 1V step, $V_S = 5\text{V}$  |           |             |              | $\text{V}/\mu\text{s}$       |
|                           |   | 4V step, $V_S = 30\text{V}$   |           |             |              | $\text{V}/\mu\text{s}$       |
| Distortion/Noise Response |   |   |           |             |              |                              |
| THD                       | Total Harmonic Distortion                   | $V_{\text{OUT}} = 2V_{\text{pp}}, f = 1\text{kHz}, G = 20\text{dB}, C_L = 100\text{pF}, V_S = 30\text{V}$ |           | 0.015       |              | %                            |
| $e_n$                     | Input Voltage Noise                         | $> 1\text{MHz}, V_S = 5\text{V}$  |           | 45          |              | $\text{nV}/\sqrt{\text{Hz}}$ |
|                           |   | $> 1\text{MHz}, V_S = 30\text{V}$   |           | 40          |              | $\text{nV}/\sqrt{\text{Hz}}$ |
| $X_{\text{TALK}}$         | Crosstalk                                   | Channel-to-channel, 1kHz to 20kHz   |           | 120         |              | dB                           |
| DC Performance            |   |   |           |             |              |                              |
| $V_{\text{IO}}$           | Input Offset Voltage <sup>(1)</sup>         | $V_{\text{OUT}} = 1.4\text{V}, R_S = 0\Omega, V_S = 5\text{V}$ to $30\text{V}$                            |           | 2           | 5            | mV                           |
|                           |   |   |           |             | <b>7</b>     | mV                           |
| $dV_{\text{IO}}$          | Average Drift                               |   |           | 7           |              | $\mu\text{V}/^\circ\text{C}$ |
| $I_b$                     | Input Bias Current <sup>(1)</sup>           | $V_{\text{CM}} = 0\text{V}$   |           | 20          | 100          | nA                           |
|                           |   |   |           |             | <b>200</b>   | nA                           |
| $I_{\text{OS}}$           | Input Offset Current <sup>(1)</sup>         | $V_{\text{CM}} = 0\text{V}$   |           | 5           | 30           | nA                           |
|                           |   |   |           |             | <b>100</b>   | nA                           |
| PSRR                      | Power Supply Rejection Ratio <sup>(1)</sup> | DC, $V_S = 5\text{V}$ to $30\text{V}$   | 70        | 100         |              | dB                           |
|                           |   |   | <b>60</b> |             |              | dB                           |
| $A_{\text{OL}}$           | Open-Loop Gain <sup>(1)</sup>               | $+V_S = 15\text{V}, R_L = \geq 2\text{k}\Omega, V_{\text{OUT}} = 1\text{V}$ to $11\text{V}$               | 85        | 100         |              | dB                           |
|                           |   |   | <b>80</b> |             |              | dB                           |
| $I_S$                     | Supply Current, CLC1050 <sup>(1)</sup>      | $R_L = \infty, V_S = 30\text{V}$  |           | <b>0.65</b> | <b>1.5</b>   | mA                           |
|                           |   | $R_L = \infty, V_S = 5\text{V}$   |           | <b>0.45</b> | <b>1.0</b>   | mA                           |
|                           | Supply Current, CLC2050 <sup>(1)</sup>      | $R_L = \infty, V_S = 30\text{V}$  |           | <b>0.7</b>  | <b>2.0</b>   | mA                           |
|                           |   | $R_L = \infty, V_S = 5\text{V}$   |           | <b>0.5</b>  | <b>1.2</b>   | mA                           |
|                           | Supply Current, CLC4050 <sup>(1)</sup>      | $R_L = \infty, V_S = 30\text{V}$  |           | <b>1.0</b>  | <b>3.0</b>   | mA                           |
|                           |   | $R_L = \infty, V_S = 5\text{V}$   |           | <b>0.7</b>  | <b>1.2</b>   | mA                           |
| Input Characteristics     |   |   |           |             |              |                              |
| CMIR                      | Common Mode Input Range <sup>(1,3)</sup>    | $+V_S = 30\text{V}$   | 0         |             | $+V_S - 1.5$ | V                            |
| CMRR                      | Common Mode Rejection Ratio <sup>(1)</sup>  | DC, $V_{\text{CM}} = 0\text{V}$ to $(+V_S - 1.5)\text{V}$   | 60        | 70          |              | dB                           |
|                           |   |   | <b>60</b> |             |              | dB                           |
| Output Characteristics    |   |   |           |             |              |                              |
| $V_{\text{OH}}$           | Output Voltage Swing, High <sup>(1)</sup>   | $+V_S = 30\text{V}, R_L = 2\text{k}\Omega$  | 26        |             |              | V                            |
|                           |   |   | <b>26</b> |             |              | V                            |
|                           |   | $+V_S = 30\text{V}, R_L = 10\text{k}\Omega$   | 27        | 28          |              | V                            |
|                           |   |   | <b>27</b> |             |              | V                            |

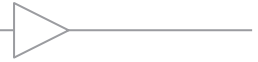

## Electrical Characteristics continued

$T_A = 25^\circ\text{C}$  (if **bold**,  $T_A = -40$  to  $+85^\circ\text{C}$ ),  $V_S = +5\text{V}$ ,  $-V_S = \text{GND}$ ,  $R_f = R_g = 2\text{k}\Omega$ ,  $R_L = 2\text{k}\Omega$  to  $V_S/2$ ,  $G = 2$ ; unless otherwise noted.

| Symbol       | Parameter                                   | Conditions  | Min       | Typ | Max       | Units         |
|--------------|---|---|-----------|-----|-----------|---------------|
| $V_{OL}$     | Output Voltage Swing, Low <sup>(1)</sup>    | $+V_S = 5\text{V}$ , $R_L = 10\text{k}\Omega$   |           | 5   | 20        | mV            |
|              |   |   |           |     | <b>30</b> | mV            |
| $I_{SOURCE}$ | Output Current, Sourcing <sup>(1)</sup>     | $V_{IN+} = 1\text{V}$ , $V_{IN-} = 0\text{V}$ , $+V_S = 15\text{V}$ , $V_{OUT} = 2\text{V}$   | 20        | 40  |           | mA            |
|              |   |   | <b>20</b> |     |           |               |
| $I_{SINK}$   | Output Current, Sinking <sup>(1)</sup>      | $V_{IN+} = 0\text{V}$ , $V_{IN-} = 1\text{V}$ , $+V_S = 15\text{V}$ , $V_{OUT} = 2\text{V}$   | 10        | 15  |           | mA            |
|              |   |   | <b>5</b>  |     |           |               |
|              |   | $V_{IN+} = 0\text{V}$ , $V_{IN-} = 1\text{V}$ , $+V_S = 15\text{V}$ , $V_{OUT} = 0.2\text{V}$ | 12        | 50  |           | $\mu\text{A}$ |
| $I_{SC}$     | Short Circuit Output Current <sup>(1)</sup> | $+V_S = 15\text{V}$   |           | 40  | 60        | mA            |

### Notes:

- 100% tested at  $25^\circ\text{C}$ . (Limits over the full temperature range are guaranteed by design.)
- The input common mode voltage of either input signal voltage should be kept  $> 0.3\text{V}$  at  $25^\circ\text{C}$ . The upper end of the common-mode voltage range is  $+V_S - 1.5\text{V}$  at  $25^\circ\text{C}$ , but either or both inputs can go to  $+36\text{V}$  without damages, independent of the magnitude of  $V_S$ .



## Typical Performance Characteristics

$T_A = 25^\circ\text{C}$ ,  $+V_S = 30\text{V}$ ,  $-V_S = \text{GND}$ ,  $R_f = R_g = 2\text{k}\Omega$ ,  $R_L = 2\text{k}\Omega$ ,  $G = 2$ ; unless otherwise noted.

Non-Inverting Frequency Response

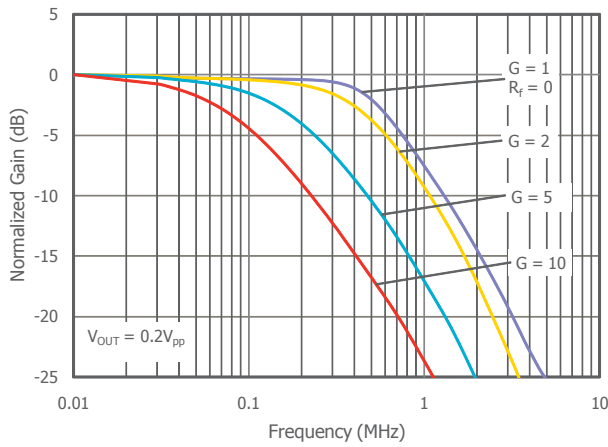

Inverting Frequency Response

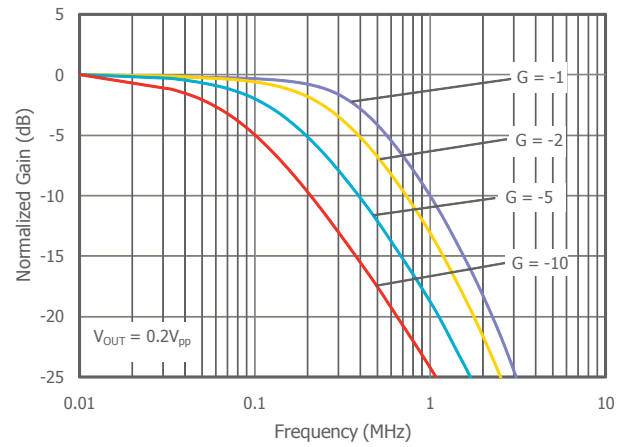

Frequency Response vs.  $C_L$

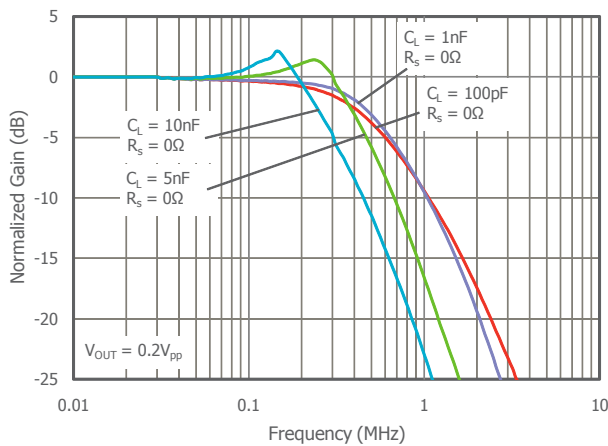

Frequency Response vs.  $R_L$

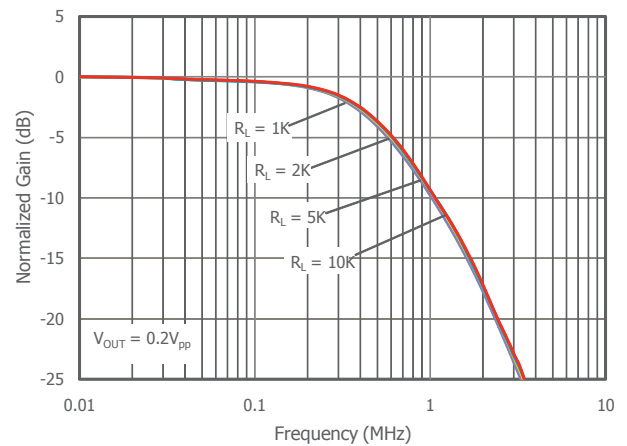

Frequency Response vs.  $V_{OUT}$

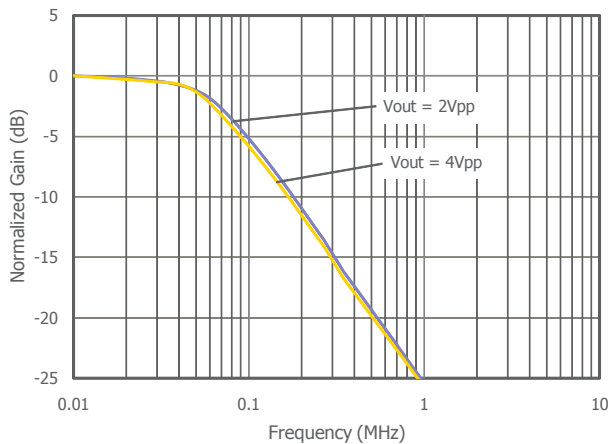

-3dB Bandwidth vs.  $V_{OUT}$

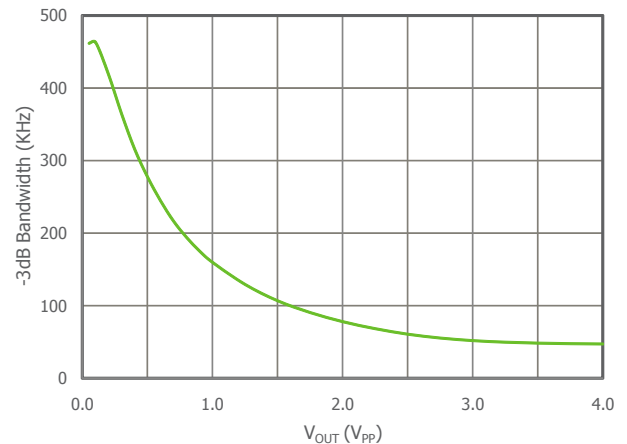



## Typical Performance Characteristics

$T_A = 25^\circ\text{C}$ ,  $+V_S = 30\text{V}$ ,  $-V_S = \text{GND}$ ,  $R_f = R_g = 2\text{k}\Omega$ ,  $R_L = 2\text{k}\Omega$ ,  $G = 2$ ; unless otherwise noted.

Non-Inverting Frequency Response at  $V_S = 5\text{V}$

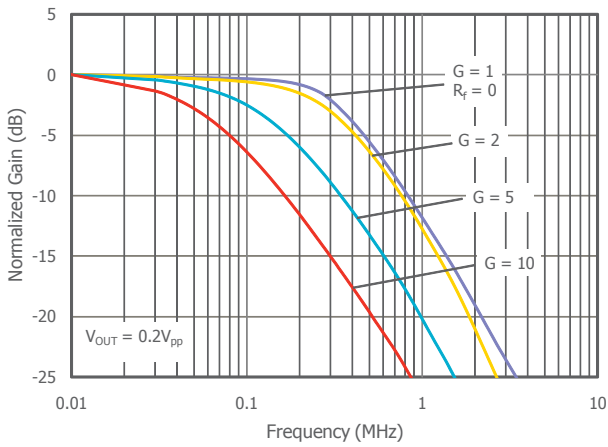

Inverting Frequency Response at  $V_S = 5\text{V}$

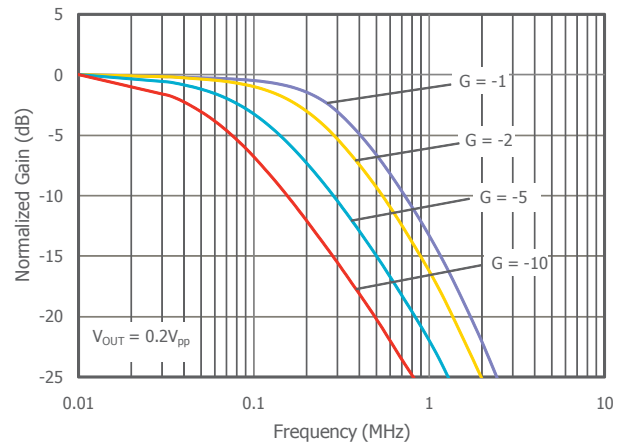

Frequency Response vs.  $C_L$  at  $V_S = 5\text{V}$

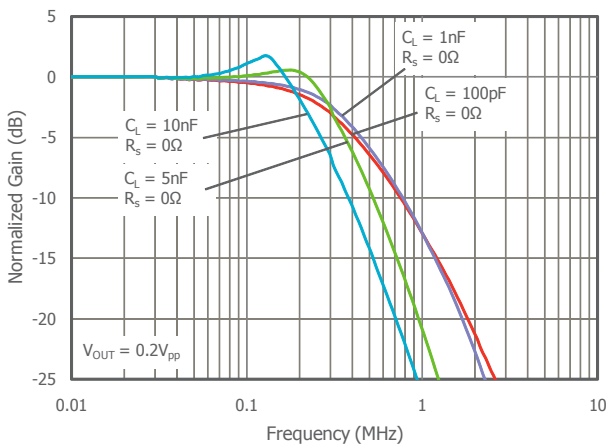

Frequency Response vs.  $R_L$  at  $V_S = 5\text{V}$

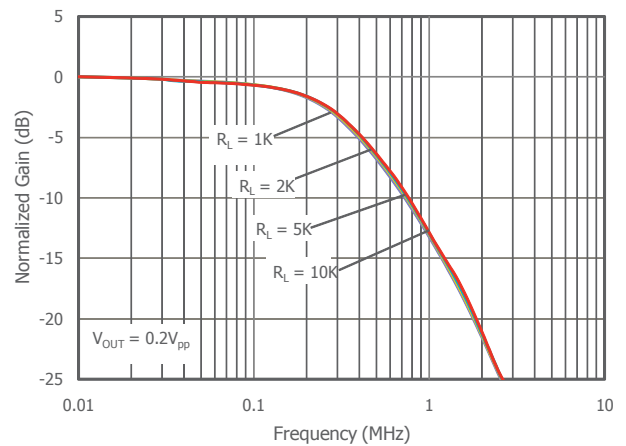

Frequency Response vs.  $V_{OUT}$  at  $V_S = 5\text{V}$

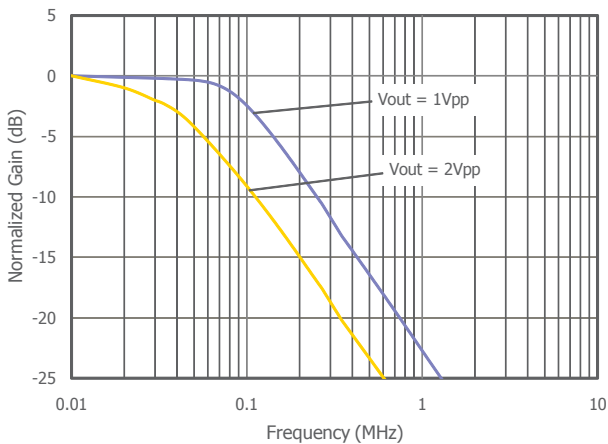

-3dB Bandwidth vs.  $V_{OUT}$  at  $V_S = 5\text{V}$

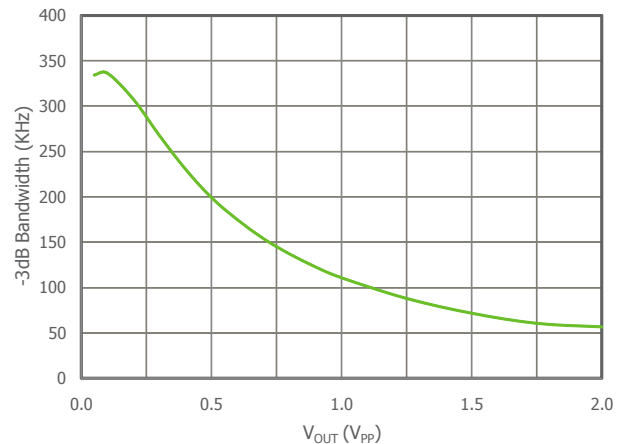



## Typical Performance Characteristics - Continued

$T_A = 25^\circ\text{C}$ ,  $V_S = \pm 5\text{V}$ ,  $R_f = R_g = 150\Omega$ ,  $R_L = 150\Omega$ ,  $G = 2$ ; unless otherwise noted.

Small Signal Pulse Response

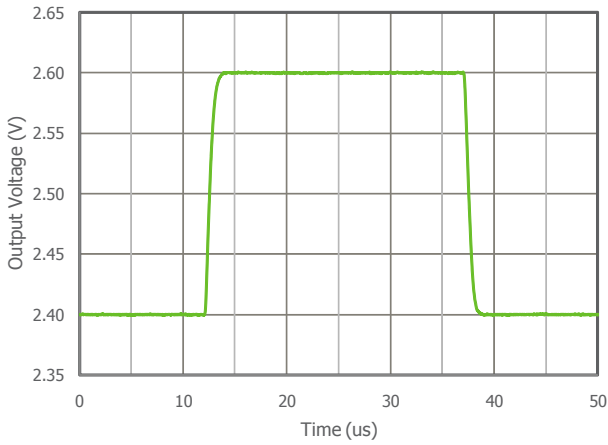

Large Signal Pulse Response

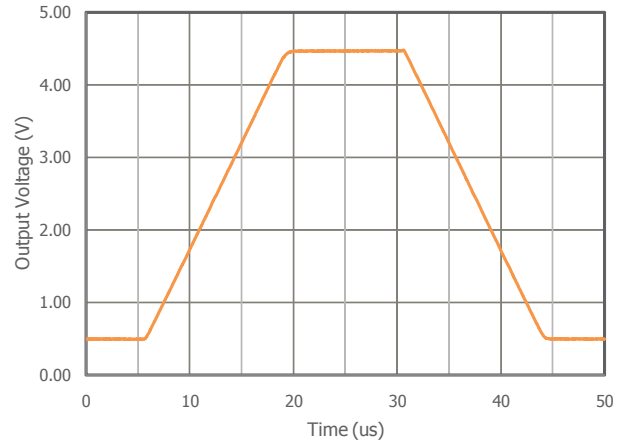

Small Signal Pulse Response at  $V_S = 5\text{V}$

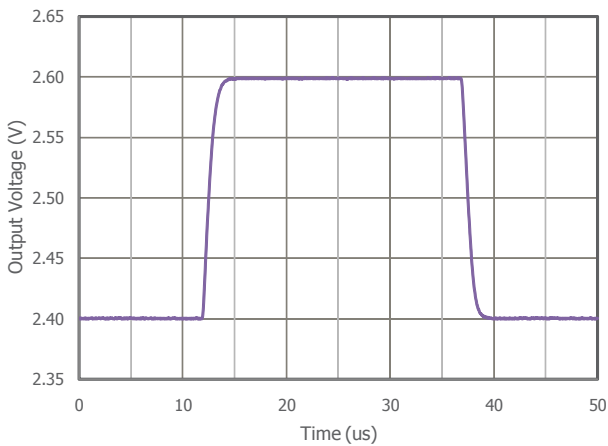

Large Signal Pulse Response at  $V_S = 5\text{V}$

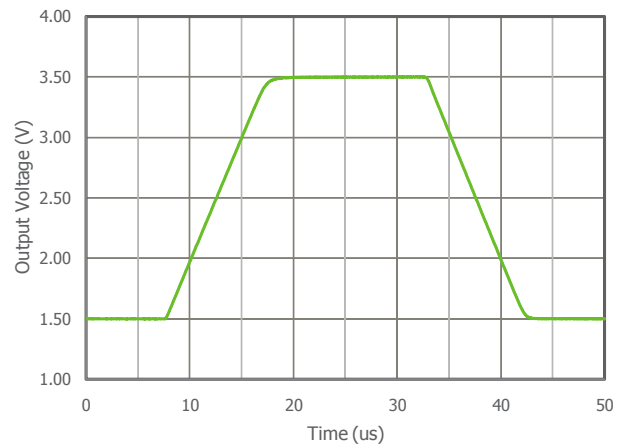

Supply Current vs. Supply Voltage

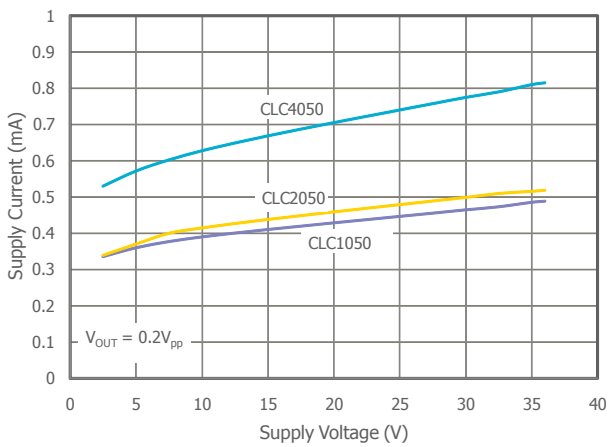

Input Voltage Range vs. Power Supply

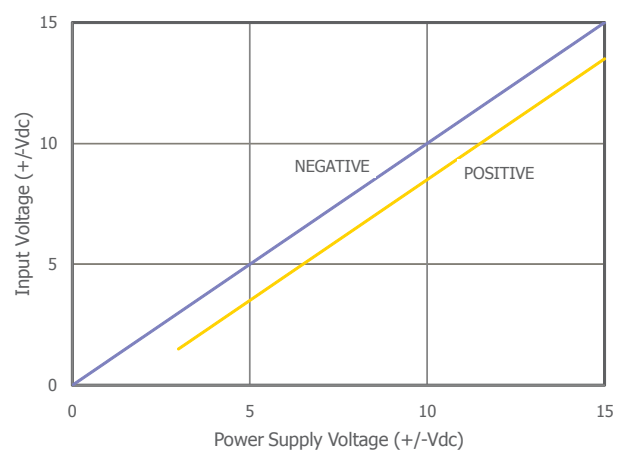



## Typical Performance Characteristics - Continued

$T_A = 25^\circ\text{C}$ ,  $V_S = \pm 5\text{V}$ ,  $R_f = R_g = 150\Omega$ ,  $R_L = 150\Omega$ ,  $G = 2$ ; unless otherwise noted.

Voltage Gain vs. Supply Voltage

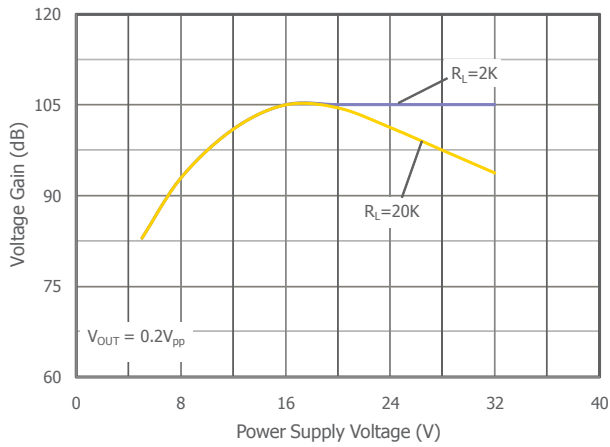

Input Current vs. Temperature

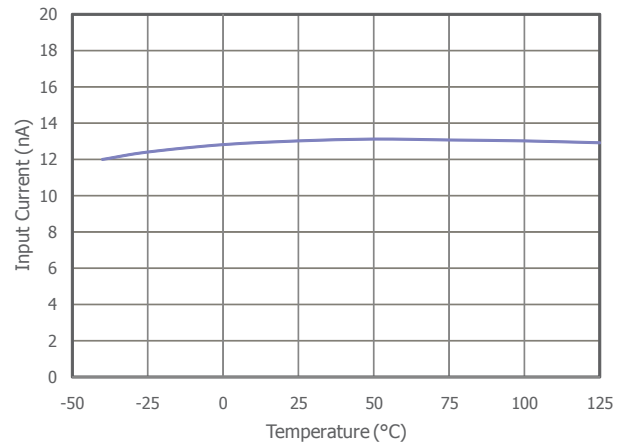

Functional Block Diagram

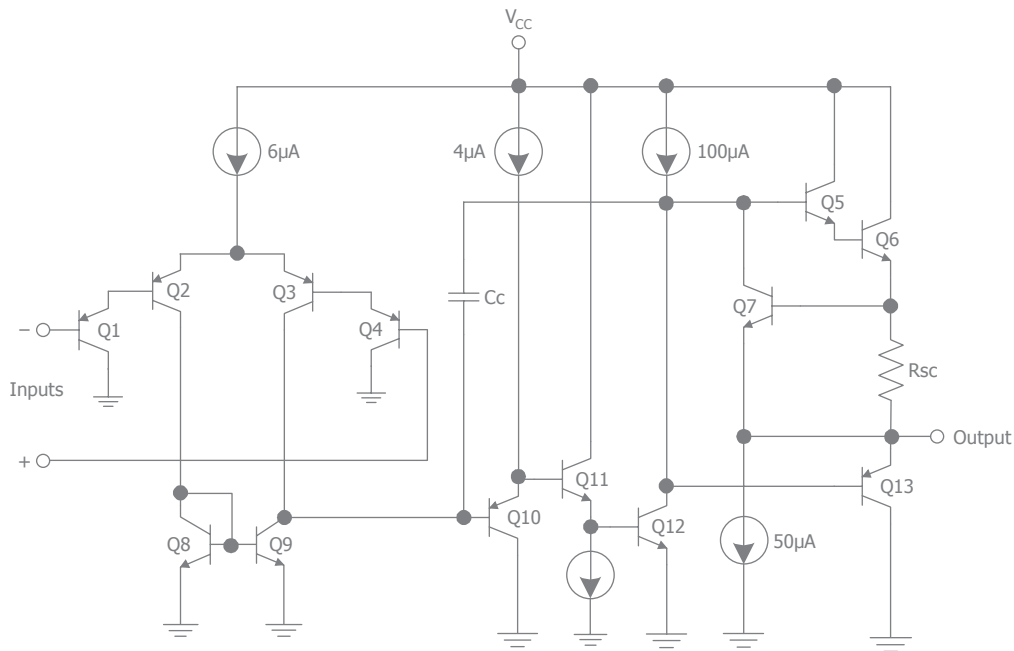



## Application Information

### Basic Operation

Figures 1 and 2 illustrate typical circuit configurations for non-inverting, inverting, and unity gain topologies for dual supply applications. They show the recommended bypass capacitor values and overall closed loop gain equations.

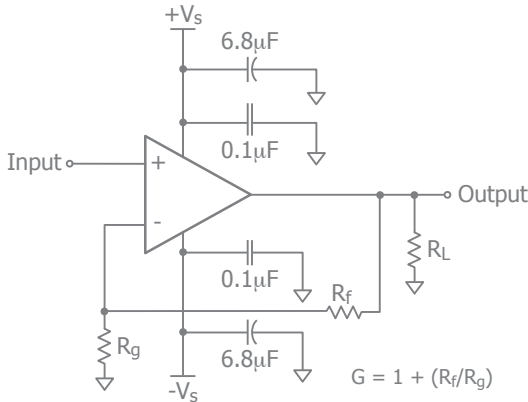

Figure 1. Typical Non-Inverting Gain Circuit

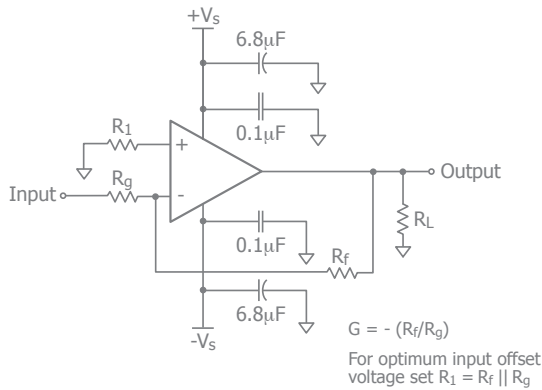

Figure 2. Typical Inverting Gain Circuit

### Power Dissipation

Power dissipation should not be a factor when operating under the stated 2k ohm load condition. However, applications with low impedance, DC coupled loads should be analyzed to ensure that maximum allowed junction temperature is not exceeded. Guidelines listed below can be used to verify that the particular application will not cause the device to operate beyond its intended operating range.

Maximum power levels are set by the absolute maximum junction rating of 150°C. To calculate the junction tem-

perature, the package thermal resistance value  $\Theta_{JA}$  ( $\Theta_{JA}$ ) is used along with the total die power dissipation.

$$T_{Junction} = T_{Ambient} + (\Theta_{JA} \times P_D)$$

Where  $T_{Ambient}$  is the temperature of the working environment.

In order to determine  $P_D$ , the power dissipated in the load needs to be subtracted from the total power delivered by the supplies.

$$P_D = P_{supply} - P_{load}$$

Supply power is calculated by the standard power equation.

$$P_{supply} = V_{supply} \times I_{RMS\ supply}$$

$$V_{supply} = V_{S+} - V_{S-}$$

Power delivered to a purely resistive load is:

$$P_{load} = ((V_{LOAD})_{RMS}^2) / R_{load\ eff}$$

The effective load resistor ( $R_{load\ eff}$ ) will need to include the effect of the feedback network. For instance,

$R_{load\ eff}$  in figure 3 would be calculated as:

$$R_L \parallel (R_f + R_g)$$

These measurements are basic and are relatively easy to perform with standard lab equipment. For design purposes however, prior knowledge of actual signal levels and load impedance is needed to determine the dissipated power. Here,  $P_D$  can be found from

$$P_D = P_{Quiescent} + P_{Dynamic} - P_{Load}$$

Quiescent power can be derived from the specified  $I_S$  values along with known supply voltage,  $V_{Supply}$ . Load power can be calculated as above with the desired signal amplitudes using:

$$(V_{LOAD})_{RMS} = V_{PEAK} / \sqrt{2}$$

$$(I_{LOAD})_{RMS} = (V_{LOAD})_{RMS} / R_{load\ eff}$$

The dynamic power is focused primarily within the output stage driving the load. This value can be calculated as:

$$P_{DYNAMIC} = (V_{S+} - V_{LOAD})_{RMS} \times (I_{LOAD})_{RMS}$$

Assuming the load is referenced in the middle of the power rails or  $V_{supply}/2$ .

Figure 3 shows the maximum safe power dissipation in the package vs. the ambient temperature for the packages available.

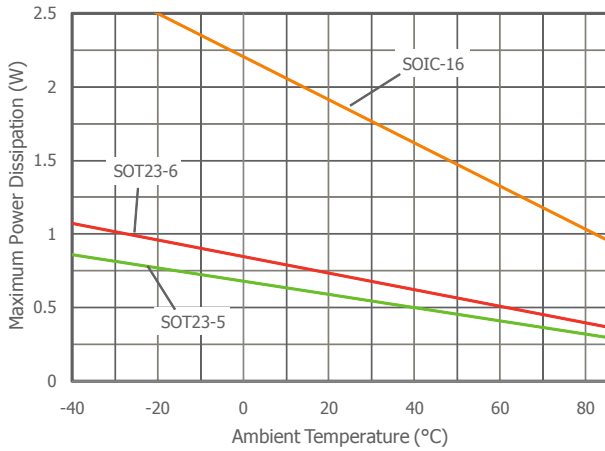

Figure 3. Maximum Power Derating

**Driving Capacitive Loads**

Increased phase delay at the output due to capacitive loading can cause ringing, peaking in the frequency response, and possible unstable behavior. Use a series resistance,  $R_S$ , between the amplifier and the load to help improve stability and settling performance. Refer to Figure 4.

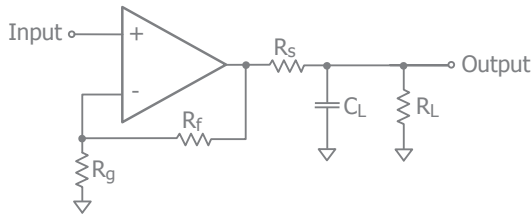

Figure 4. Addition of  $R_S$  for Driving Capacitive Loads

Table 1 provides the recommended  $R_S$  for various capacitive loads. The recommended  $R_S$  values result in  $\leq 1$ dB peaking in the frequency response. The Frequency Response vs.  $C_L$  plot, on page 6, illustrates the response of the CLCx050.

| $C_L$ (pF) | $R_S$ ( $\Omega$ ) | -3dB BW (kHz) |
|------------|--------------------|---------------|
| 1nF        | 0                  | 485           |
| 5nF        | 0                  | 390           |
| 10nF       | 0                  | 260           |
| 100        | 0                  | 440           |

Table 1: Recommended  $R_S$  vs.  $C_L$

For a given load capacitance, adjust  $R_S$  to optimize the tradeoff between settling time and bandwidth. In general, reducing  $R_S$  will increase bandwidth at the expense of ad-

ditional overshoot and ringing.

**Overdrive Recovery**

An overdrive condition is defined as the point when either one of the inputs or the output exceed their specified voltage range. Overdrive recovery is the time needed for the amplifier to return to its normal or linear operating point. The recovery time varies, based on whether the input or output is overdriven and by how much the range is exceeded. The CLCx050 will typically recover in less than 30ns from an overdrive condition. Figure 5 shows the CLC1050 in an overdriven condition.

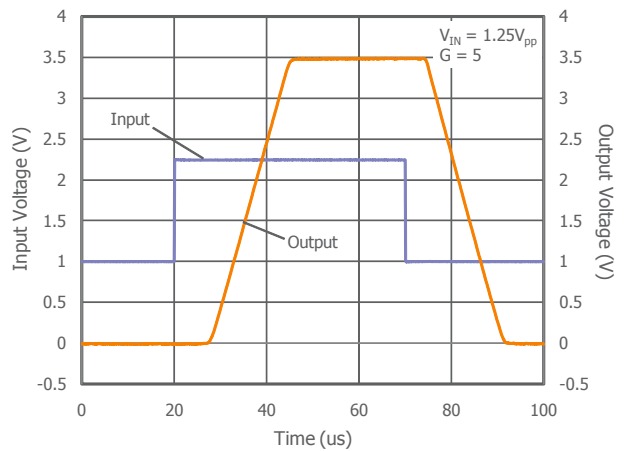

Figure 5. Overdrive Recovery

**Layout Considerations**

General layout and supply bypassing play major roles in high frequency performance. CADEKA has evaluation boards to use as a guide for high frequency layout and as aid in device testing and characterization. Follow the steps below as a basis for high frequency layout:

- Include 6.8 $\mu$ F and 0.1 $\mu$ F ceramic capacitors for power supply decoupling
- Place the 6.8 $\mu$ F capacitor within 0.75 inches of the power pin
- Place the 0.1 $\mu$ F capacitor within 0.1 inches of the power pin
- Remove the ground plane under and around the part, especially near the input and output pins to reduce parasitic capacitance
- Minimize all trace lengths to reduce series inductances

Refer to the evaluation board layouts below for more information.



### Evaluation Board Information

The following evaluation boards are available to aid in the testing and layout of these devices:

| Evaluation Board | Products |
|------------------|----------|
| CEB002           | CLC1050  |
| CEB006           | CLC2050  |
| CEB018           | CLC4050  |

### Evaluation Board Schematics

Evaluation board schematics and layouts are shown in Figures 9-14. These evaluation boards are built for dual-supply operation. Follow these steps to use the board in a single-supply application:

1. Short -Vs to ground.
2. Use C3 and C4, if the -Vs pin of the amplifier is not directly connected to the ground plane.

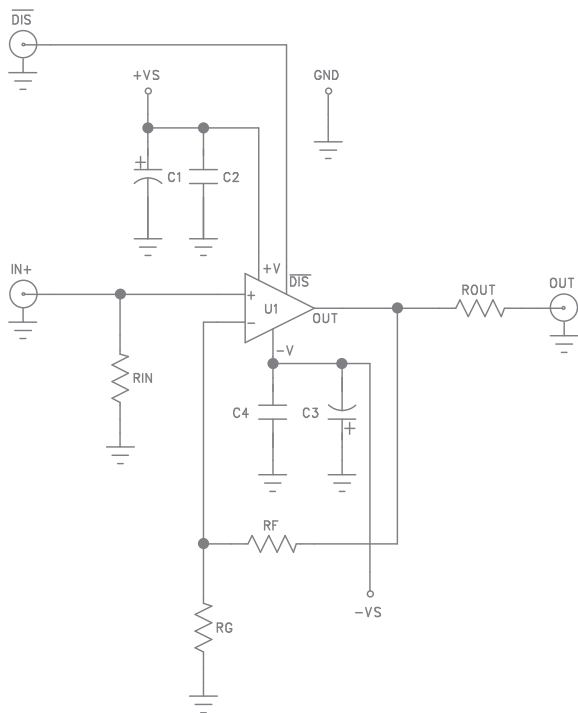

Figure 9. CEB002 Schematic

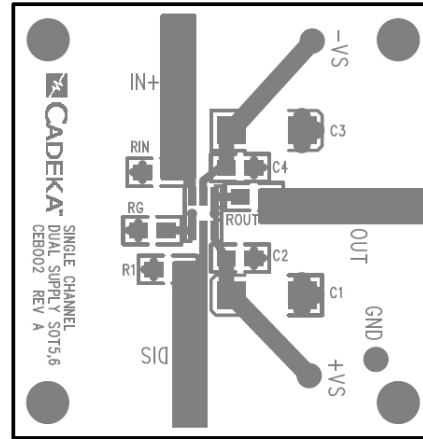

Figure 10. CEB002 Top View

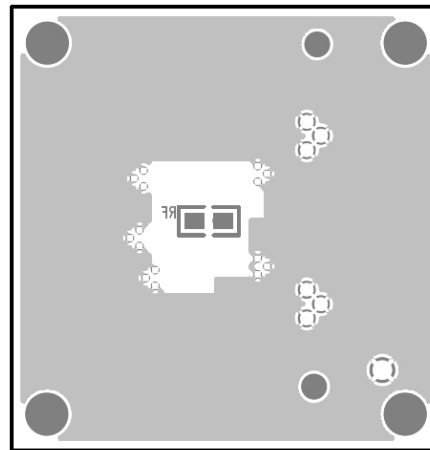

Figure 11. CEB002 Bottom View

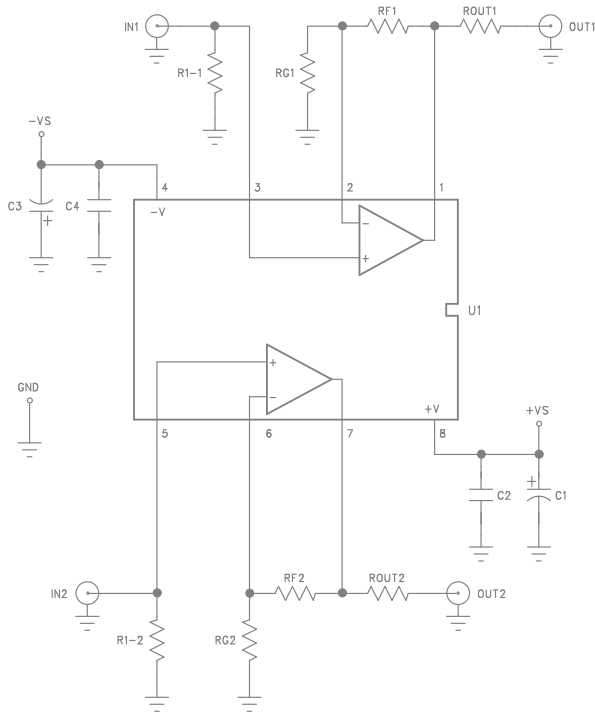
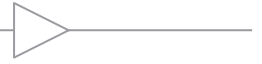

Figure 12. CEB006 Schematic

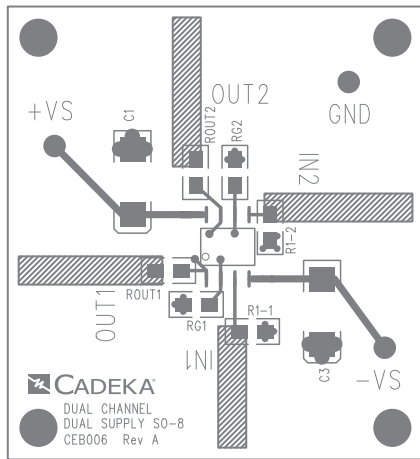

Figure 13. CEB006 Top View

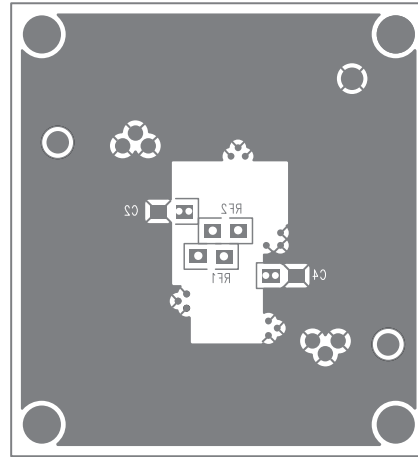

Figure 14. CEB006 Bottom View

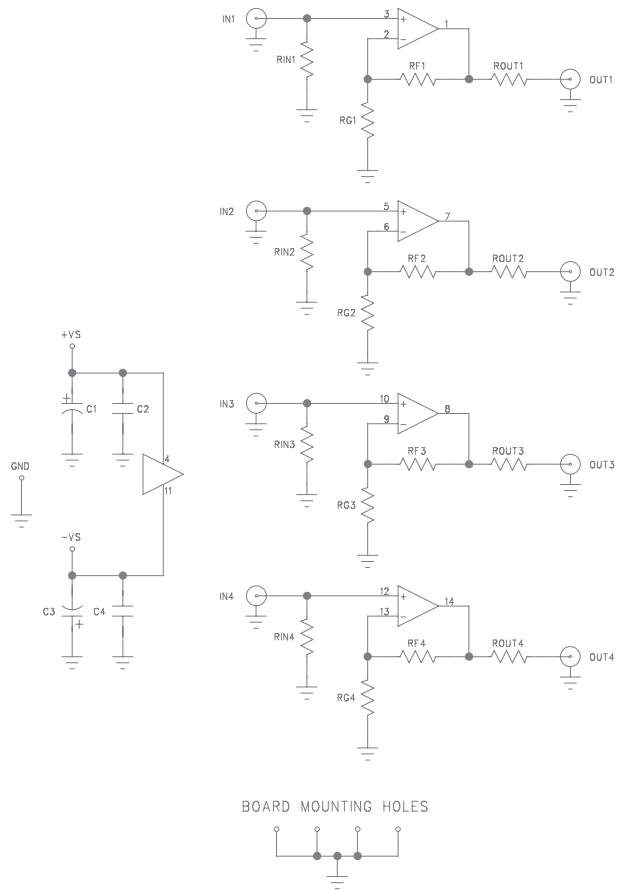

Figure 15. CEB018 Schematic

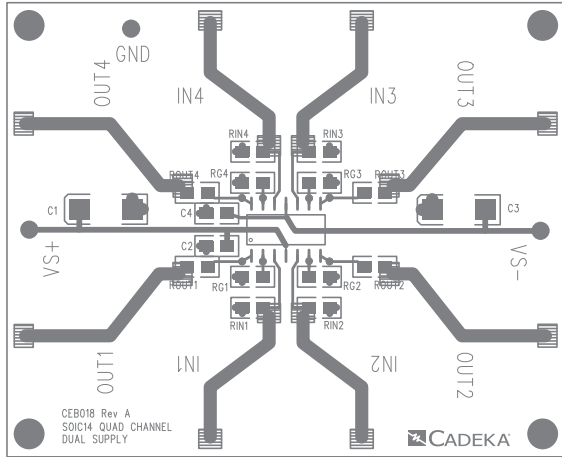

Figure 16. CEB018 Top View

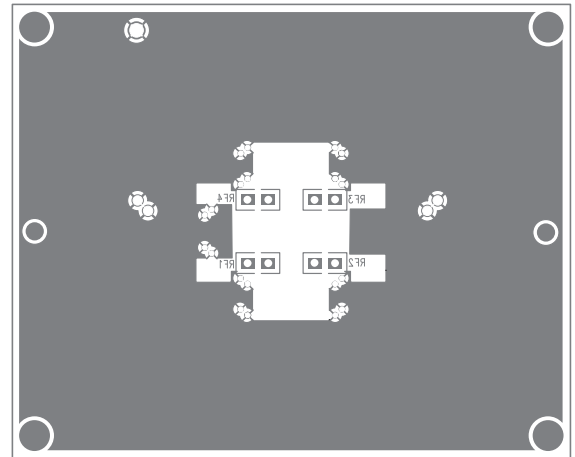

Figure 17. CEB018 Bottom View

### Typical Applications

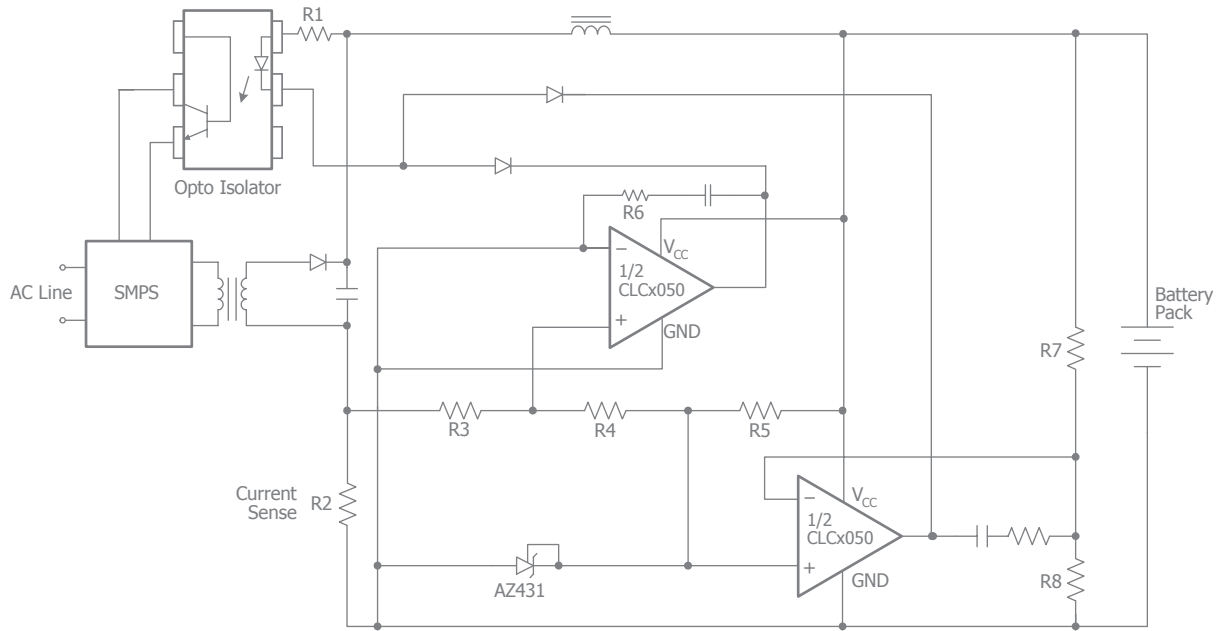

Figure 18. Battery Charger

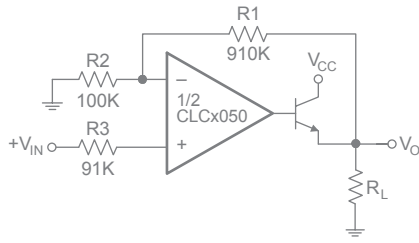
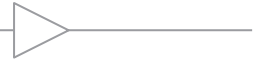

Figure 19. Power Amplifier

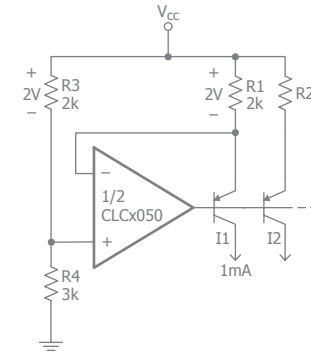

Figure 22. Fixed Current Sources

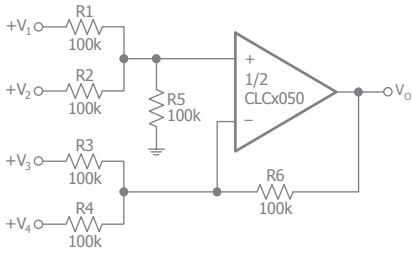

Figure 20. DC Summing Amplifier

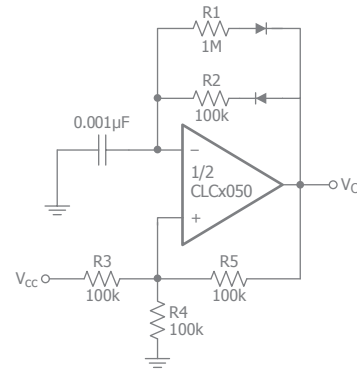

Figure 23. Pulse Generator

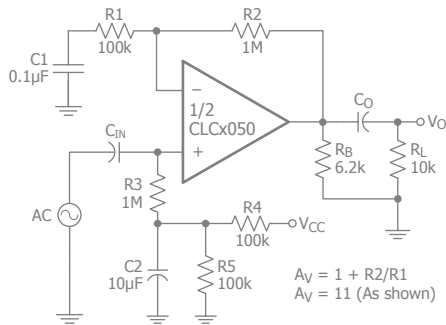

Figure 21. AC-Coupled Non-Inverting Amplifier

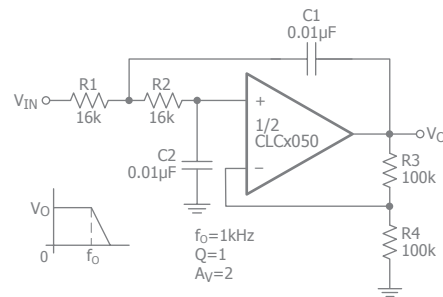
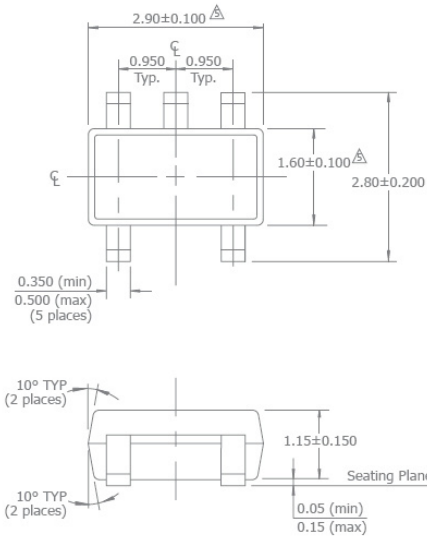

Figure 24. DC-Coupled Low-Pass Active Filter



## Mechanical Dimensions

### SOT23-5 Package



**NOTES:**

1. Dimensions and tolerances are as per ANSI Y14.5M-1982.
  2. Package surface to be matte finish VDI 11~13.
  3. Die is facing up for mold. Die is facing down for trim/form, ie. reverse trim/form.
  4. The footlength measuring is based on the gauge plane method.
- △ Dimension are exclusive of mold flash and gate burr.  
 △ Dimension are exclusive of solder plating.

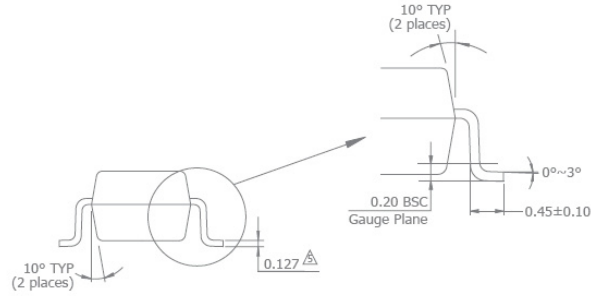

### SOIC-8 Package

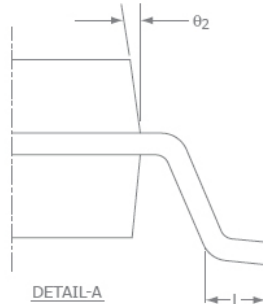
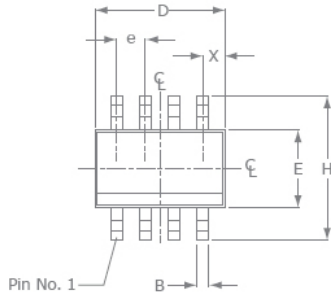

| SOIC-8 |          |      |
|--------|----------|------|
| SYMBOL | MIN      | MAX  |
| A1     | 0.10     | 0.25 |
| B      | 0.36     | 0.48 |
| C      | 0.19     | 0.25 |
| D      | 4.80     | 4.98 |
| E      | 3.81     | 3.99 |
| e      | 1.27 BSC |      |
| H      | 5.80     | 6.20 |
| h      | 0.25     | 0.5  |
| L      | 0.41     | 1.27 |
| A      | 1.37     | 1.73 |
| θ1     | 0°       | 8°   |
| X      | 0.55 ref |      |
| θ2     | 7° BSC   |      |

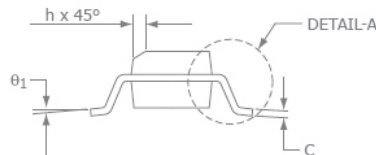
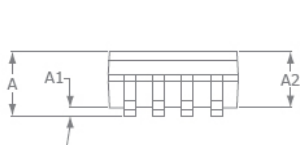

**NOTE:**

1. All dimensions are in millimeters.
2. Lead coplanarity should be 0 to 0.1mm (0.004") max.
3. Package surface finishing: VDI 24~27
4. All dimension excluding mold flashes.
5. The lead width, B to be determined at 0.1905mm from the lead tip.



## Mechanical Dimensions continued

### SOIC-14 Package

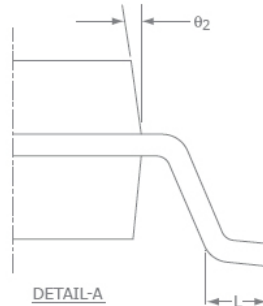
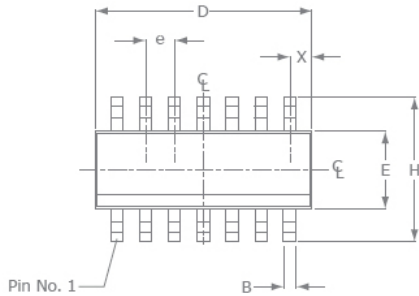

| SOIC-14    |          |      |
|------------|----------|------|
| SYMBOL     | MIN      | MAX  |
| A1         | 0.10     | 0.25 |
| B          | 0.36     | 0.48 |
| C          | 0.19     | 0.25 |
| D          | 8.56     | 8.74 |
| E          | 3.84     | 3.99 |
| e          | 1.27 BSC |      |
| H          | 5.80     | 6.20 |
| h          | 0.25     | 0.5  |
| L          | 0.41     | 1.27 |
| A          | 1.37     | 1.73 |
| $\theta_1$ | 0°       | 8°   |
| X          | 0.51 ref |      |
| $\theta_2$ | 7° BSC   |      |

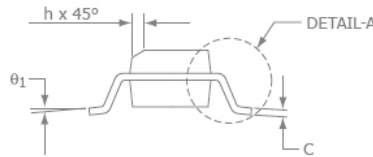
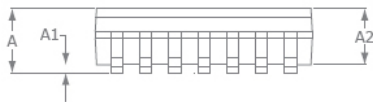

**NOTE:**

1. All dimensions are in millimeters.
2. Lead coplanarity should be 0 to 0.1mm (0.004") max
3. Package surface finishing: VDI 24~27
4. All dimension excluding mold flashes.
5. The lead width, B to be determined at 0.1905mm from the lead tip.

For additional information regarding our products, please visit CADEKA at: [cadeka.com](http://cadeka.com)

**CADEKA Headquarters** Loveland, Colorado  
 T: 970.663.5452  
 T: 877.663.5452 (toll free)

CADEKA, the CADEKA logo design, COMLINEAR, the COMLINEAR logo design, and ARCTIC are trademarks or registered trademarks of CADEKA Microcircuits LLC. All other brand and product names may be trademarks of their respective companies.

CADEKA reserves the right to make changes to any products and services herein at any time without notice. CADEKA does not assume any responsibility or liability arising out of the application or use of any product or service described herein, except as expressly agreed to in writing by CADEKA; nor does the purchase, lease, or use of a product or service from CADEKA convey a license under any patent rights, copyrights, trademark rights, or any other of the intellectual property rights of CADEKA or of third parties.

Copyright ©2007-2008 by CADEKA Microcircuits LLC. All rights reserved.

